

ORCA[®]

Blinky Pro

ETS

MODEL:
BP1001

INSTRUCTION MANUAL

VERSION 1.4

Thank you for choosing ORCA Products. Welcome to the power and convenience of Brushless RC. By purchasing the BP1001 Competition Brushless Electronic Pro Blinky Speed Control ("ESC") you have chosen one of the most advanced speed controls in RC Racing. The BP1001 allows customization for multiple programmable parameters and the only one ORCA speed control that uses the button esc without program card to program the esc. (If using the ESC's Program Card which can be purchased separately). Please read this manual thoroughly to familiarize yourself with the installation, setup and operation. By operating this product, you accept the ORCA Warranty

SPECIFICATION

*** 32 bit processor	*** Low resistance FET
*** Continuous current System:	*** Auto Fan control
Forward/Brake/Reverse:	Brushless
Dimensions:	Yes (Factory preset at Forward/Brake)
Weight:	30.45(L)x30.35(W) x 10.35(H)mm
Voltage Input:	20.80g (excluding wires)
Peak Current:	6V-11V
Continuous current :	380A
Motor Limit:	100A
Motor Type:	Over 10.5Turns
B.E.C.:	Sensored 540 sized brushless motors
Multi Protection System:	4A_6V
	Yes

INSTALLATION & CONNECTORS

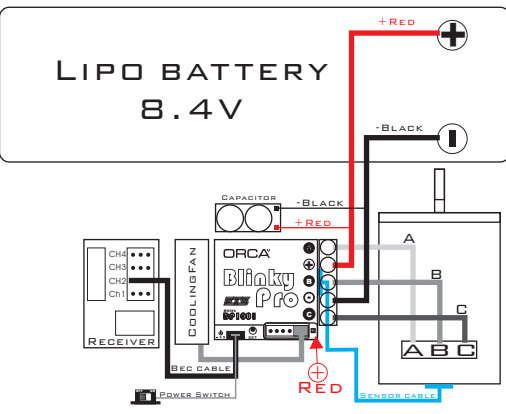

- * Install/Solder the relevant battery connector (Battery Specific) to the battery wires. Red to +ve and Black to -ve. (WARNING! Reversing the battery polarity will destroy your ESC and void the warranty.)
- * Connect supplied BEC wire (150mm) to 3pin port match the (+ + s) between the receiver connector and ESC.
- * Connect the 3 motor wires to the motor; you can either solder the wires directly to the motor or use your favorite connectors. Match the label of the ESC Output (A, B, C) to the Tab/labels on the motor when soldering. Avoid soldering each joint for longer than 5 seconds. Prior to operation make sure you have not created a short by either creating a wire bridge or solder bridge on the solder tabs on the motor. (WARNING! Improper wiring may damage the ESC and void the warranty.)

- * Connect the sensor cable between the ESC sensor plug and the Motor sensor plug.
- * Connect the receiver plug to the CH2/throttle pin of the receiver.
- * Secure the on/off switch in a place where it will not be accidentally knocked to the off position during a crash.
- * The Fan port voltage is drawn directly from the battery.

RADIO & ESC SETUP

Transmitter Settings:
 Throttle Travel Maximum / 100%
 Brake Travel Maximum / 100%
 Throttle Exponential Start with 0%
 Throttle Neutral Trim Center / 0
 Throttle Servo Reverse Reverse (Futaba, KO, Sanwa)
Initial set-up of the throttle end-points of the ESC:
 * Connect the power wires of the ESC to a fully charged battery set; making sure the polarity is correct.
 * Bind your receiver and transmitter first if your radio requires you to do so.
 * Turn on the transmitter and hold the throttle at full brake position.
 * Turn on ESC and listen for 2 beeps.
 * After you hear the 2 beeps, apply full throttle and listen for another 2 beeps.
 * Once you hear the 2 beeps, release the throttle to neutral position.
 * A beep will then sound, signifying that the ESC endpoints have been successfully set.
Note! If you do not hear the beeping sound as described above, try reversing the throttle reverse setting in the transmitter.

CUSTOMIZING THE ESC

Due to the different requirements of each style and class of racing, it is important to customize your ESC for each use case. Customization of the ESC is done using the Program Card (Sold Separately):



To begin, connect the battery wires to a charged battery, then connect supplied 4pin wire (200mm) to the ESC setting port (4pin port) and Program Card. Turn on the ESC and the Program Card will activate automatically. Note that the screen will show "Loading?? during initialization -indicating that the ESC is copying the current setup in the ESC to the Program Card. Once loading is completed, the screen will show "ETS Blinky Pro" and "Program". You can now begin programming your ESC. Press "Enter" to access Program Mode.

TIPS! Whenever in doubt, double check your ESC setting by initializing the Program Card again and checking each menu setting. Navigation around the Program Menu is done using the 4 buttons on the right hand side of the Program Card. The function of each button varies depending on which screen the display is showing:
 "Select" button-----go to next select
 Press and Hold "Select" button two second -----go to back page
 ▲ button - Scroll up
 ▼ button - Scroll down
 "Enter" button - Send Changes from Program Card to the ESC and overwrite old data in the ESC

NOTE! The Program Card is not included and is sold separately. The Program Card will compare the Parameters within the card and ESC before sending. If changes are detected, you will hear a series of beeps and the Program Card will display:



TIPS! Do not worry about making mistakes. You will not damage the ESC during setting. If in doubt, you can always reload the default set up and start over again.

OPERATION

Getting started
 Turn on the on/off switch, the screen will display:



Use ▲ button and ▼ button to find [Program], [Data Record] or [Update]. Press ▲ button to choose. Each mode presented are independent from each other and will require setup.

Press "SELECT" button for 2 seconds to go back to the previous screen.

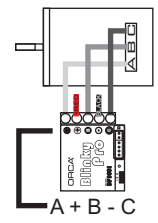
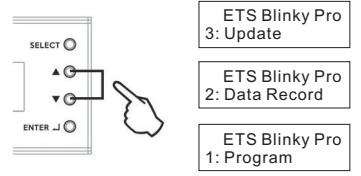

1. Program
 Enter direct go to setup page, 1:RunningMode Forward/Brake

Use "SELECT" button go to next setup item "2:BatteryCutOff" or "3:Punch or 4-10.

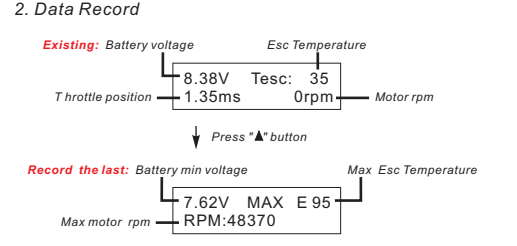

Double press "Enter" button to clear the data, otherwise Min and Max data will keep Forever.

3. Update

Updating of ESC Firmware:
 * Scroll to the "Update" menu and press "Enter". This will show the current ESC Firmware Version.
 * Press "Enter" again to access the SD cards Firmware folder. Select the firmware Version that you would like to use to update the ESC. Press "Enter" again and the update will commence (It will take around 1 minute to complete the update).



Updating of Program Card Firmware:
 * Depress and hold the Program card "Enter" button while turning on the ESC. It will display the current Program card firmware Version.
 * Press "Enter" again to access the SD cards Firmware folder. Select the Firmware Version that you would like to use to update the Program Card. Press "Enter" again and the update will commence (It will take around 1 minute to complete the update).

Preparing the SD card for use:
 Format a microSD card using FAT32 file structure using a personal computer. If you are using a Micro SD Card larger than 32GB, you will need to use a 3rd party SW Package to do this. Create a new folder called "Firmware". Download the latest firmware from www.orcarc.com/firmware/ and copy the file to the "Firmware" folder on the Micro SD card. Once completed, install the MicroSD card into the microSD card slot of the Program Card. Both the Program Card and ESC Firmware Files need to be copied in the "Firmware" Folder. A maximum of 10 of each ESC/Program card firmware can be present in the folder at any one time.

OPERATING TIPS

Multi Protection System -- In addition to the Low Voltage and Overheat Protection that were described above, the ESC is protected in 2 more ways.

ESC auto temperature protect
 * The esc will auto down power to 50% when the esc temperature over 125F degree

Motor Lock Protection:
 * The motor have not temperature protection in this esc but the ESC is protected against damage when the motor is stuck and does not turn at all. Power will not be applied in this situation.
 * CAUTION! Since the ESC relies on the feed back of the 3 motor wires to deploy this protection, it ONLY works if the motor does not turn AT ALL. If the rotor has any rotation, the ESC will consider the motor to be operational and the power to the motor will not be cut off.

Fail Signal Protection:
 * In case the radio signal to the ESC is interrupted for over 1 second during a run, the ESC will cut off until the signal resumes.

Misc. Tips:
 * Connect the ESC to the battery pack only when you are ready to run. This will avoid draining the battery pack. Always disconnect the battery after your run.
 * A small spark may occur when the battery is initially connected to the ESC. This is normal and is due to the charging of the capacitors.

All ORCA products are manufactured in accordance with the highest quality standards. ORCA guarantees this product to be free from defects in materials or workmanship for 60 days from the original date of purchase verified by sales receipt. This limited warranty does not cover damages resulting from abnormal wear, misuse or improper maintenance of the product. To avoid unnecessary service and mailing charges, always eliminate all other possibilities and check all components for malfunctions before sending in your unit for repair. Products sent in for repair that operate perfectly will be charge a service fee. When sending in the product, always pack carefully and include the original sales receipt, a description of the problem encountered, your return address and contact information. Since we do not have control over the installation and use of this product, we cannot accept any liability for any damages resulting from the usage of this product. Therefore, using this product is at your own risk, and the user accepts all resulting liability from installing and using of the product.

Setting by Program Card

PROGRAM	
A + B - C	
C + B - A	

↓ Press "Enter" button ↓

Press "Select" button to next function

1. Running Mode	Forward/Brake	Forward/Brake
	Forward/Rev	
2. Battery Cut Off	LiPolymer Low 2.9V	Middle
 Middle 3.2V	
 High 3.4V	
	Disabled	
3. Punch	1-5	5
4. PWM	1000	8000
	4000	
	8000	
	12000	
	16000	
	24000	
5. Drag Brake	Off	Off
	5%	
	10%	
	20%	
	50%	
	100%	
6. Max Brake Force	off	100%
	20%	
	40%	
	60%	
	80%	
	100%	
7. Brake Punch	1-5	5
8. Brake PWM	1000	1000
	2000	
	4000	
9. Reverse Force	25%	50%
	50%	
	75%	
	100%	
10. Neutral Range	3%	6%
	6%	
	9%	
	12%	
	15%	

Setting by ESC set Button

Functions	Participate	Blue light Flash					
		Flash one time	Flash two time	Flash three time	Flash four time	Flash five time	Flash six time
1. Running Mode	Red light flash one time	Forward/Brake	Forward/Rev	Forward/brake/Rev			
2. Battery Cutoff Voltage	Red light flash two time	LiPolymer Low	LiPolymer Middle	LiPolymer High	Disabled		
3. Punch	Red light flash three time	Level1	Level2	Level3	Level4	Level5	
4. PWM	Red light flash four time	1K	4K	8K	12K	16K	24K
5. Drag Brake	Red light flash five time	OFF	5%	10%	20%	50%	100%
6. Max. Brake Force	Red light flash six time	OFF	20%	40%	60%	80%	100%
7. Brake Punch	Red light flash seven time	Level1	Level2	Level3	Level4	Level5	
8. Brake PWM	Red light flash eight time	400Hz	600Hz	800Hz	1K	2K	4K
9. Max. Reverse Force	Red light flash nine time	25%	50%	75%	100%		
10. Neutral Range	Red light flash ten time	3%	6%	9%	12%	15%	

How to use the button to setup the ESC without program card: (Transmitter must be turned on during setup the ESC without program card.)

1. Connect the power wires of the ESC to a fully charged battery set; making sure the polarity is correct.
2. Use the 1.5mm screw to press the set hole button before switching on the ESC, switch on the ESC and then hold the button continuously about 2 seconds to wait the LED light off and hear the motor long beep sound appear.
3. Set hole button only to let you choose the function mode, red LED will flash one time to eleven times representing which function you want to set.
4. Transmitter will let you change the participate of each function, full throttle once time will increase one participate e.g. (the blue LED will flash two times from one time), full brake once time will decrease one participate e.g. (the blue LED will flash one time from two times).
5. When you finish setup you can switch off the ESC directly, it can save automatically.

All ESC setup back to factory out:

Use the 1.5mm screw to press the set hole button before switching on the ESC, switch on the ESC and then hold the button continuously about 2 seconds to wait the LED light off and hear the motor long beep sound and then keep continuously pressing the set button until the green LED light fast flash, release the set button and switch off the ESC. (Make sure pressing the set button continuously until the green LED light fast flash, otherwise please repeat the setup again.)

Detailed Explanation of each Function item:

- 1) **Running Mode**
Forward/Brake-----This function the car will not have reverse function, just forward and brake.
Forward/Rev-----This function the car will reverse immediately when the throttle brake the car.
Forward/Brk/Rev---Set this function the first touch of throttle brake the car will have brake function, and if you release to center position after brake and continue brake again the reverse function will appear.
- 2) **Battery Cut off Voltage**
LiPolymer Low-----Lipo cut off at 2.9V/cell
LiPolymer Middle -----Lipo cut off at 3.2V/cell
LiPolymer High-----Lipo cut off at 3.4V/cell
- 3) **Punch**
Allows you to change the punch of the ESC (Level 1 to Level 5):
* Level 1 has the least punch and Level 5 has the highest punch.
* Adjust punch level to maximize acceleration speed with minimum wheel spin.
- 4) **PWM (Driver Freq)**
Allows you to change the forward drive frequency of the ESC (1K to 24K From six step)
* The 1K setup will give you good punch at the low end.
* The 24K setup will result in strong mid to top end.
* Experiment to find out what suits your driving style best.
- 5) **Drag Brake**
Set the automatic brake force applied when the throttle returns to neutral position (6 steps from Off to 100%):
* 50% and 100% Drag Brake recommend used in Crawl only.
- 6) **Max Brake Force**
Control the Maximum Brake power when you full braking
- 7) **Brake Punch**
When you set Punch 5, the brake time will follow your throttle brake simple and direct, if you used Punch 1-4 the brake feeling have something ABS, get more smooth.
- 8) **Brake PWM (Brake Freq)**
Brake PWM operates similar to PWM except it affects the braking instead of the throttle (6 steps from 400hz to 4khz)
* At 400 Hz, the Drag brake and the Brake force will feel the punchiest.
* At 4k Hz, the Drag brake and the Brake will feel smooth.
- 9) **Max Reverse Force**
Control the Maximum Reverse power when you Reverse the car.
- 10) **Neutral Range**
Set the sensitive relay to your throttle feeling, normally set in 6%.